



GUIDANCE FOR TOWAGE OPERATIONS IN CLYDEPORT



Issue Orig: 31 January 2019

CONTENTS

INDEX	Page
Contents	2
Section One – Introduction	
1.1 Introduction	5
1.2 Responsibilities for a towage evolution	5
1.3 Clydeport requirements	6
Section Two - Responsibilities	
2.1 Introduction	7
2.2 Clydeport Expectations	7
Section Three – Tug and Tow Operations Entering or Leaving the Port	
3.1 Introduction	10
3.2 Requirement to provide Information	10
3.3 Timing to provide Information	10
3.4 Submission of Information.	10
3.5 Unusual Tows and/or Project cargoes	11
Section Four – Overview of Regulations	
4.1 Introduction	12
4.2 Clydeport Area	12
4.3 Regulations and Requirements	13
4.4 Pilotage Requirements	13
4.5 Communication	13
4.6 Anchors	13
4.7 Miscellaneous Requirements	14
4.8 Incident Reporting	14
Section Five – Passage Planning	
5.1 Introduction	15
5.2 Responsibility for Voyage Planning	15
5.3 Pilotage Input	15
5.4 The Passage Plan	16
5.5 Identifying the Risks	16
5.6 Charts and Electronic Navigational Aids onboard	16
5.7 Berthing/unberthing; Tidal Flow considerations	17
5.8 Contingency Planning for Emergencies and Unforeseen Events	17
Section Six – Testing, Inspection & Maintenance of Towing Equipment	
6.1 Introduction	18
6.2 Items to be Checked Before and After Towing	18
6.3 Recording of Inspections	19
6.4 Formal Testing and Maintenance of Towing Equipment	19

6.5	Acceptable Safety Factors for Towing Equipment	19
Section Seven – Preparations before Commencing Towing Operations		
7.1	Introduction	20
7.2	Preparations onboard the Tug	20
7.3	Preparations onboard the Craft to be Towed	21
7.4	Loading Barges	21
7.5	Spoil Cargoes	22
Section Eight – Crew Safety during Towage Operations		
8.1	Introduction	23
8.2	Working Hours	23
8.3	Safety of Personnel	23
8.4	Effective Communications	24
8.5	General Safety Provisions	24
8.6	Briefings/Tool Box Talks/Risk Assessments	25
Section Nine – Making up a Tow and Making Fast to Tugs		
9.1	Towage arrangements	26
9.2	Position of Barges	26
9.3	Making Barges Fast Together	29
9.4	Navigation Lights and Shapes	29
Section Ten – Underway and Manoeuvring of the Tow		
10.1	Introduction	30
10.2	Manoeuvring Alongside	30
10.3	Pushing Ahead or Towing Alongside	30
10.4	Craft Tug Towing Limitations	30
10.5	Towing in Rough Weather	30
10.6	Towing East of No1 Buoy.	32
10.7	Towing North of the Cumbrae Gap up to Kempock Point	32
10.8	Towing in Restricted Visibility	32
10.9	Clydeport definitions of Day and Night Operations	32
Section Eleven – Mooring Barges		
11.1	Introduction	33
11.2	Mooring Barges Alongside Tidal berths	33
11.3	Shearing Barges at a Tidal Berth	34
11.4	Mooring Barges in the Clyde.	36
Section Twelve – Further Guidance and Advice		37
Annexes		
A. Extract British Tug Owners Association Checklists.		
Appendices		

1. Clydeport Tow Notification Form	
2. Peel Ports Marine Accident Report Form	
3. Marine Guidance Note 564(M+F) Marine Casualty and Marine Incident Reporting.	

Section One – Introduction

1.1 Introduction

Clydeport recognises that towage operations in the port require particular skills to ensure the safety of persons, property and the environment. Clydeport has a requirement that adequate planning is concluded to satisfy the Port Authority each evolution has a Passage Plan that has resulted from proper assessment of the risk, mitigation ALARP, persons deployed have appropriate knowledge and training and that equipment is fit for purpose of the evolution intended. Production of this information by the responsible party will enable Clydeport to consent the evolution proceeds.

1.2 Responsibility for a towage evolution

A towage evolution may involve multiple parties with an interest in the voyage. The role of each must be clearly identified and their individual responsibility(ies) known to all.

Participants may comprise a combination of:

Tug Master

Master of a tug retains at all times responsibility for the safety of the tug and crew. Responsibility for any vessels being towed may vary with different evolutions and tow contract(s).

Towage Operator

Tug owner/operator has responsibility to ensure the tug has crew appropriately qualified and trained for the work they are required to undertake, and that the vessel and its equipment are both adequately maintained and assessed fit for purpose of the evolution intended.

Barge Owner

The owner of the barge (or other object being used in tow) has responsibility for their property and persons who may be carried on board. Any variation to this must be clearly identified to Clydeport prior to the evolution and the transferee of responsibility acknowledge their acceptance.

Barge Master

A Barge Master must be appointed for all non-standard towage operations, be suitably qualified and experienced for the evolution, properly identified and with responsibility for planning before commencement of the voyage. This person is expected to have responsibility for stability of the barge when in laden condition and prosecution of the voyage.

Mooring Crew

Clydeport requires assurance the tug and/or barge(s) will properly be secured within the Port when not underway. The party responsible must clearly be identified for all aspects of the voyage within the Port.

Other Party

This category may include but not be limited to charterer, cargo owner(s), project manager or project sub-contractor. The other party may be the main beneficiary of the voyage being undertaken. Clydeport expectation is this third party is the person identified as having overall responsibility to execute the

voyage. In event the other party will not attend during the evolution then it is required an attending representative will be identified by other party.

1.3 Clydeport requirements

Prior to commencement of the evolution:

- Information is provided to COL adequately in advance of the evolution
- Clearly identified person with overall responsibility
- Clarity of the respective roles and responsibility of all attending parties
- Details of the how the evolution is insured (or self-insured)
- Good working knowledge of the river and local traffic
- Submission of information must not exclude:
 - Passage plan (berth to berth)
 - Contingency planning
 - Tow Notification Form fully completed
 - RAMS, specific to the evolution
 - Bollard Pull calculation based on recommended format and specific to the evolution intended

A booking for the evolution is made in PortLinks

Evolution does not proceed without consent

During the evolution

- Communications/reporting requirement of the Port are strictly adhered
- AIS signal is provided to assist traffic monitoring
- Incidents are promptly Reported to Clydeport

Clydeport expects:

- Due recognition by all parties of and adherence to Industry Practice
- Recognition of and adherence to Clydeport Directions (incl. Pilotage Directions)
- Testing, inspection and maintenance of towing equipment

Section Two – Responsibilities

(for consideration when intending a towage evolution)

2.1 Introduction

Towage and manoeuvring of barges, light or heavily loaded with cargo or equipment, is a specialist and skilled job. The difficulty is compounded within the Port where conflict with significant marine traffic (commercial, ferry, naval and leisure) is likely. A good working knowledge of the Clyde regime and environment, especially in the river section East of No1 buoy, is essential. This document aims to provide guidance and advice on craft towage in the Clyde waters and illustrates examples of associated local good practice.

2.2 Clydeport Expectations

Tug Master

Tug Masters (and crew) should ensure that:

- All onboard pre-departure checks are completed before getting underway;
- Any risk assessments required are completed and applied before engaging in towage operations and that relevant personnel have sighted them;
- All crew are fit, properly rested, trained for the task to be carried out and have correct PPE;
- Crew are properly briefed on the work to be carried out and clear knowledge of 'escape' plans;
- Good communication is established and maintained between the Tug Master and crew at all times during towage operations;
- Towing gear is in date for certification and testing, checked in good operational condition and fully prepared for use (towing equipment should be inspected both before and after towage operations);
- All watertight hatches and doors are kept closed whilst towing to maintain the watertight integrity of the vessel(s).

Tug Owner/ Operator

Vessel operators should carefully note their responsibilities under Rule 2 of the International Regulations for Preventing Collisions at Sea (COLREGS). Additionally, Health and Safety at Work Regulations require employers to provide a safe working environment for all employees. This means setting out a clear Health and Safety Policy available to all crew, including risk assessments for all tasks to be carried out and information relating to the duties of all crew members. Considering this, it is prudent for vessel operators to:

- Implement an effective Health and Safety Policy and operational Safety Management System of which all employees are aware and have access to;
- Ensure that Tug Masters and crew are appropriately qualified for the work asked of them, with the relevant endorsements (particularly the towing and pushing endorsement) and ancillary training;
- Ensure that crew are correctly trained for the duties they are required to perform. Training sessions should be frequent and should be logged to create a clear audit trail. This training should cover
 - The capabilities and limitations of the towing equipment and the use of their associated safety systems; and

- The necessary response to emergency situations such as fire, flood, collision, grounding, girting and parted tows which should be laid down, known to crews and regularly practiced.
- Introduce a system of risk assessments and briefings for standard operations to be used by Tug Masters as standard operating procedures, prior to engaging in towing operations;
- Ensure through risk assessment that the vessels being used in towing operations are the most suitable, taking into account likely conditions, physical restrictions, limitations of vessels, competency of crew and provision of onboard equipment;
- Undertake separate risk assessments where an unusual towing operation is to be undertaken or where a standard operation is to be changed (i.e. introducing a new facility, barge, tug or route);
- Introduce a clear policy on drug and alcohol use;
- Introduce a system of checklists detailing standard operating procedures for such tasks as:
 - Operational Procedures;
 - Maintenance Routines;
 - Pre-Sailing Checks, and
 - Checks to be completed before and after towing.
- Ensure that there is frequent communication between management and employees by establishing clear lines of communication, and
- Ensure that information such as Notice to Mariners, appropriate Codes of Practice, Merchant Shipping Notices, Marine Guidance Notices etc. are efficiently promulgated to Master/Skipper and crew.

It is the responsibility of the vessel operator to provide a safe working environment and to create a safety conscious culture within the company ensuring all crew are correctly trained to undertake required duties. Additionally, Merchant Shipping regulations put responsibility on both the vessel operator (or owner) and the Master to ensure that the crew are suitably rested.

Barge Master or designated Responsible Person

A Barge Master or responsible person must be appointed for all non-standard towage operations (see Section 3.5). The Barge Master must be a person suitably qualified and experienced to take on the role; and must be identified and appointed by the party with overall responsibility before planning for the non-routine towage operation commences. The Barge Master has the following roles and responsibilities:

- Co-ordinating the planning, preparation and rehearsal(s) for the towage operation;
- Developing a comprehensive operational risk assessment for the entire operation, and presenting it to Clydeport;
- Preparing and submitting a passage plan and details of the towing configuration to the Clydeport;
- Determining the proposed manning and competency requirements for all personnel (excluding any pilots) involved in the operation.
- Overall responsibility for the safety and conduct (where no pilot is embarked) of the towage operation and the passage and
- Ensuring that a proper record and audit trail of the planning and approval process and the operation itself, is maintained.

Pilot

Certain towage operations in the Clyde are subject to compulsory pilotage (see section 4.4). Additionally, Clydeport may require one or more Pilots are engaged for unusual towage operations (See Section 3.5).

Pilot has the following roles and responsibilities:

- Providing advice and additional support in the planning, risk assessment and rehearsal(s) for any non-routine towage operations;
- Providing local knowledge, information and advice to the Barge Master and/or other party responsible for the evolution;
- Notwithstanding the responsibilities of the Barge Master and/or Tug Master, taking conduct of the navigation of the tug and tow(s);
- Immediately advising Clydeport on any aspect of the towage operation that gives cause for concern;
- Acting as Clydeport representative on board; undertaking a liaison role on behalf of the Senior Manager Marine Operations (SMMO) as circumstances require

Note: In all cases, the Tug Master retains command of and is responsible for his tug and crew.

Section Three – Tow Notification

All towage activity within the Port requires, under General Direction, advance notification to and consent of Clydeport.

3.1 Introduction

Clydeport operates under the Port Marine Safety Code and recognises the Guide to Good Practice on Port Marine Operations. Pursuant to responsibility of the Port Authority, including that arising under the PMSC (GTGP Section 10) Clydeport Operations Limited, (Statutory Harbour Authority), requires notification and details of all towing activity within the Port Area.

3.2 Requirement to provide Information

The party responsible for a towage operation must ensure specified information is provided to Clydeport). This information is to;

- Confirm that operators are conducting towage operations in the Clyde with adherence to Industry recognised standards;
- Ensure the towage operation is undertaken in all respects fit-for purpose;
- Assist any authorised Pilot allocated to the vessel to understand the nature and limitations of the towage operation;
- Ensure all parties involved in and supporting the towage operation are aware/informed.

3.3 Timing to provide Information

Tow Notification Form and supporting documentation must be submitted to Clydeport and received by 12:00 on the working day preceding the evolution (Monday to Friday), and by 12:00 on Fridays for weekend moves up to 16:00 on the Monday, or Tuesday if there is a Bank Holiday Monday.

For moves requiring Pilotage support, the documentation must be submitted 48 hours in advance of the move Monday to Friday, and by 16:00 on Thursdays for weekend moves up to 16:00 on the Tuesday, or Wednesday if there is a Bank Holiday Monday.

Note: In order not unnecessarily to delay Clydeport's consent, when complex/unusual moves are intended, advance notice may require information is provided 3 weeks before the proposed evolution.

Clydeport (ClydeMarineManagers@peelports.com) may require a consultation meeting is convened, requiring attendees including pilot representatives, harbour towage operators, supporting marine services and sponsors of the project to support consent for the towage evolution.

3.4 Submission of Information

The information required may be provided directly or via an Agent and must be submitted for the attention of Clydeport (ClydeMarineManagers@peelports.com).

The provisional order for a Pilot (if required) will not be accepted until all the information is provided. Portlinks should be used to book the Pilot.

Clydeport recognises a need to support commercial operations. At the sole discretion of the SMMO, a shorter notification period to provide information may be permitted. However, in all cases, requirement remains to ensure the full process below is followed and the documentation is of an acceptable standard. Information required:

Fully completed Tow Notification Form (Appendix 1) – all sections must be completed. The Form will be considered properly completed only if it contains:

- A Navigation Risk Assessment;
- Method Statement for the requested towage operation;
- Completed Risk Assessments and Method Statements to cover all associated activities (including personnel transfers between vessels; Personnel transfer between craft and the shore/quayside; movement of plant on/off the vessel/barges; etc.);
- A passage plan (berth-berth) OR at least the boundary of the Port to/from the berth/final destination;
- Details of any additional supporting vessels involved in the operation within the port (e.g. tug or workboat assistance) including vessel names, owner/operator and Master contact details, rendezvous points, change-over berth and agreed operations plans;
- Any restrictions or limitations of the vessels engaged in the towage operation; planned towing speed, max wind limits; max tidal flow limits; air draughts and clearances;
- Details of all restrictions imposed by Insurers on the towage operation;
- Evidence of appropriate insurance, (including pollution and wreck removal cover);
- Plan and arrangements for mooring; backup/contingency/refuge/anchoring and/or securing the tow at its final (and interim) destination(s) in the port.
- Bollard Pull Towage Calculation (minimal standard based on the formula described in Transport Canada TP119660E, Appendix A, Guidance for Tug and Barge Towing Systems).
- Notification of carrying dangerous goods as defined in the IMDG Code and/or Dangerous Goods in Harbour Areas Regulations 2016.

The check off list at Annex A, as a minimum, should be used as an *aide memoir*.

3.5 Unusual Tows and/or Projects

For project cargo/complex/non-standard moves, comprehensive planning is the key to a successful outcome. Parties planning to undertake these types of tow must make contact with Clydeport (ClydeMarineManagers@peelports.com) as early as possible, to ensure the towing operation is conducted in a safe manner. Clydeport may require a consultation meeting is convened with pilot representatives; harbour towage operators; supporting marine services; sponsors of the project and their relevant associates for this phase of the project. This is intended to ensure all parties are fully briefed on all aspects of the intended evolution, engaged and capable fully to support the towage requirement. These types of tow will invariably require pilotage support services. A Consultation Charge will be levied depending on the extent of involvement and advice of Clydeport Marine staff.

Section Four – Overview of Port Regulations

4.1 Introduction

Clydeport as the Statutory Harbour Authority, requires notification and details of all towing activity within the Port Area.

4.2 Clydeport Area

The Clydeport area of Jurisdiction includes the River Clyde, its estuary and adjacent Sea Lochs. Activity in Loch Long and/or Gareloch falls under the Dockyard Port Clyde and will require further consultation and approval of Queens Harbour Master.

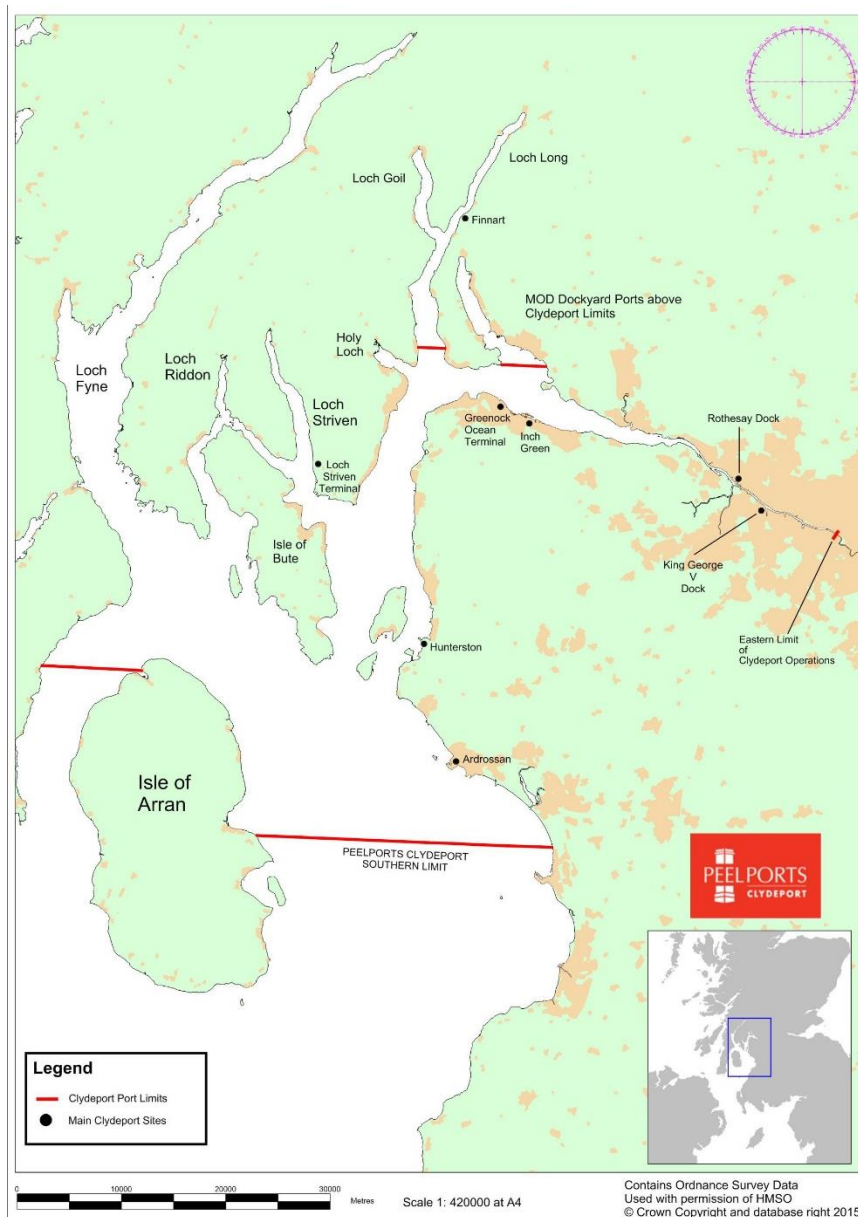

DRAWING TO BE CHANGED – DYP BOUNDARY IS MISLEADING

4.3 Regulations and Requirements

Throughout the Clydeport jurisdiction COLREGS are the primary regulations and the Master of any vessel must have a thorough knowledge and understanding.

Clydeport expects Masters/Skippers have made reference to Clydeport website (www.peelports.com), Byelaws, General Directions, latest Charts, Tide Tables and to current editions of Sailing Directions, List of Radio Signals etc.

Tug and workboat Masters must also have knowledge of Clydeport Notices to Mariners which can be found on <https://www.peelports.com/marine-information?port=clydeport>.

4.4 Pilotage Requirements

Current Pilotage Directions are published on the Peel Ports website on the link above. Vessel/Barges carrying dangerous goods as defined in the IMDG Code and/or Dangerous Goods in Harbour Areas Regulations 2016, must be declared on the Tow notification form and will require a Pilot from/to Cumbrae Gap or berth to berth.

4.5 Communication

All Towing Operations must be supported by a good communications plan, in place and established prior to the evolution commencing.

Radio Communication

As a minimum, VHF Channel 12 must be monitored on a continuous watch by the towing vessel. Ship to ship and ship to shore operating communication channels (VHF/UHF) and procedures, including any supporting visual methods (hand signals/flag hoists), must be clear and available to all parties prior to the voyage commencing. The communication plans must be included in the Method Statement.

Automatic Identification System (AIS)

All towing vessels must be fitted with operational AIS and transmitting during the towage operation, including when at anchor. AIS is not a substitute for keeping a proper lookout or navigating in accordance with the Rules.

If AIS equipment becomes defective, Estuary Radio must be informed immediately on VHF Ch12. Thereafter, update to be provided to Estuary Radio (LPS) every 30 minutes on position course and speed. This will enable a manual injected track to be generated and assist the LPS operator to give other vessels accurate traffic information.

Back up Communication

Exchange of mobile phone contact numbers for key personnel involved, in particular the Tug Master, mooring gang leader and Clydeport LPS, as a communication backup is highly recommended, and details should be submitted on the Tow Notification Form.

4.6 Anchors

General Requirements

All parties undertaking towage operations in the Clyde should be fully aware of anchorage arrangements, taking into account the displacement of any object(s) towed and requirements given the nature and configuration of the operations being undertaken.

In particular, tug and barge combinations that involve pushing ahead or towing alongside should be provided with an effective bow anchor or stern anchor meeting the requirements of Section 20 of the MCA Workboat Code. During pushing and towing alongside operations, use of the tug's bow anchor would be inappropriate; either a bow anchor should be provided on the barge (in the event of pushing operations), or a stern anchor should be provided on the tug or barge when towing alongside.

Additional Requirements for Vessels Navigating the River Clyde East of No 1 Buoy

Tug and barge combinations that involve pushing ahead or towing alongside, navigating the River Clyde East of No 1 buoy, where the combined length of the tug and barges exceeds 35m, must submit a formal risk assessment to Clydeport to address the anchoring arrangements of the tow combination. Operations will typically require stern anchors on towed barges.

4.7 Miscellaneous Requirements

Wheelhouse Visibility – Pushing Operations

Due to substantial leisure activity in the Firth of Clyde (11 marinas and numerous rowing/kayak/diving clubs) and creel fishing activity, it is vital that Masters of pushing vessel have adequate forward visibility to enable small craft, buoys and markers to be sighted in sufficient time to take avoiding action. To establish reasonable visibility, Clydeport recommends a minimum wheelhouse visibility, allowing the Helmsman to see an object 1m in height at a distance of not more than 66m from the bow of the vessel. See Figure 1 below.



Fig 1 – Wheelhouse visibility recommendations for tugs/workboat and tow navigation in the Clyde.

4.8 Incident Reporting

Clydeport has a responsibility to ensure appropriate action is taken to discharge the duties of the Harbour Authority, following incidents and to promote safe practice in order discouraging future incidents causing a danger to navigation.

All Marine Incidents must be reported via the Peel Ports Marine Accident Report form, at Appendix 2, to; ClydeMarineManagers@peelports.com .

Marine Incidents include 'Near Miss' situations, with incident/accident categories as defined by the Marine Guidance Note 564 (M + F) (Appendix 3).

Section Five – Passage Planning

5.1 Introduction

The development of a plan for voyage or passage, as well as continuous monitoring of the vessel's progress and position during the execution of such a plan, are essential for safety of life at sea, safety and efficiency of navigation and protection of the marine environment.

The requirement for passage planning applies to all vessels. There are several factors that may impede the safe navigation of all vessels and additional factors that may impede the navigation of large vessels or vessels carrying hazardous cargoes. These factors will need to be fully considered in the preparation of and in subsequent monitoring of the execution of the plan.

Passage planning includes appraisal, i.e. gathering all information relevant to the contemplated voyage or passage; detailed planning of the whole voyage or passage from berth to berth, including those areas necessitating the presence of a pilot; execution of the plan; and the monitoring of the progress of the vessel in the implementation of the plan.

5.2 Responsibility for Passage Planning

It is customary on sea-going commercial vessels, the Master has responsibility for but delegates the initial task for preparing the passage plan to the Navigating officer. The Navigating officer will prepare the detailed plan from berth to berth, in accordance with Guidelines for Voyage Planning, Annex 25 IMO Resolution A.893(21) and to the Master's requirements. If the port/berth of destination is not known or is subsequently altered, the Navigating officer must extend or amend the original plan as appropriate.

On tugs, the Master (or Skipper) is unlikely to have a Navigating officer and will undertake the entire Passage Planning exercise.

5.3 Pilot Input

The passage plan covers the voyage from berth to berth and therefore including any pilotage stage. The IMO Guidelines do not give specific advice on this important stage. The following notes should be taken into consideration when planning and executing the pilotage stage(s).

Pilots make a significant contribution to the safety of navigation in the confined waters and port approaches of which they have up to date knowledge. However, responsibilities of the vessel's navigational (bridge) team and the officer of the watch do not transfer to the pilot.

The Pilot will be advised by the Master of the manoeuvring characteristics and basic details of the vessel for its present condition. The intended passage plan should be consulted with the Pilot and any amendments agreed and documented.

The Master must ensure that the Pilot is fully integrated into and his functions supported by the other members of the Bridge team. Attention is drawn to the following extract from IMO Resolution A.285 (VIII):

“Despite the duties and obligations of a pilot, his presence on board does not relieve the officer of the watch from his duties and obligation for the safety of the vessel. He should co-operate closely with the pilot and maintain an accurate check on the vessel's position and movements. If he is in any doubt as to the pilot's actions or intentions, he should seek clarification from the pilot and if doubt still exists he should notify the master immediately and take whatever action is necessary before the master arrives.”

5.4 The Passage Plan

The foundations of the Plan are:

- **Appraising** all relevant information
- **Planning** the intended voyage
- **Executing** the plan taking account of prevailing conditions
- **Monitoring** the vessel's progress against the plan continuously

5.5 Identifying the Risks

Safe interaction with other traffic requires the person navigating and in charge of the tug being suitably qualified, experienced and competent. This person must be fully conversant with general navigation and have a thorough understanding and proper application of the COLREGS and local rules and regulations. Clear and comprehensive instructions for navigation watch keeping should be set out in the tug's Safety Management System.

The safety benefits of passage planning are recognised throughout the marine world. The benefits are not limited to reducing risks to coastal or deep-sea passages. The principles apply equally to navigation within the Firth of Clyde and River Clyde. This is recognised by Clydeport and a requirement for all towing operations.

Clydeport expects Tug Masters in the port have experience sufficient to demonstrate a thorough knowledge of the Clyde, be fully aware of the potential risks to their vessel/tow and have developed and follow a generic passage plan for routine towage and navigation in the port.

The generic passage plan should address the principal and consistent hazards, which could endanger the towing operation. Additional safety issues relating to a specific evolution (cargo or trip on a particular day in the circumstances of the towage operation being performed), the generic plan must be amended as appropriate. The generic plan should, as a minimum, address the following issues:

- The route to be taken;
- The normal expected arrival and departure points;
- The size and type of vessels towed;
- The tidal conditions expected during the operation with particular attention to percentages of spring tides, local weather conditions and recent/current rainfalls.
- Anticipated vessel traffic levels, pinch points and unusual operations;
- Areas sensitive to wash and recommended speed at which to pass;
- Identified static hazards and areas of danger en-route;
- Areas of reduced depth and tidal limitations
- Any air draught limitations and bridge transits.

More detailed guidance on passage or voyage planning is available at SOLAS Chapter 5 Annexes 24 & 25.

5.6 Charts and Electronic Navigational Aids

Towing vessels must carry the appropriate charts for their area of operation and should have an electronic chart plotter, with up to date chart corrections. Clydeport survey charts (in .pdf format) of sections of the River and in some areas on the Firth of Clyde are available to download from the Peel Ports website, in the Marine Information/Clydeport section, under Hydrographic Information (<https://www.peelports.com/marine-information?port=clydeport>).

5.7 Berthing/unberthing; Tidal Flow considerations

When berthing and unberthing, due consideration should be had to tidal flow effects, especially in Spring tides or during periods of, or just after, heavy rainfall. Timings as indicated in the Towage Matrix should be considered as guidance, but for any riverside berth East of No1 buoy, berthing and unberthing on the last 2 hours of the ebb tide should be avoided. Likewise, entering/leaving the Great Harbour, Rothesay Dock, KGV Basin and any other basin off the River Clyde on the last 2 hours of the ebb needs careful consideration.

5.8 Contingency Planning for Emergencies and Unforeseen Events

The vessel's generic passage plan and safety management system should incorporate tried and tested procedures for dealing with onboard emergencies and unforeseen circumstances.

Such events include, but are not be limited to:

- Loss of main propulsion power;
- Loss of electrical power;
- Failure of steering and/or other control systems;
- Man overboard;
- Engine room fire;
- Bridge or accommodation fire;
- Parted tows;
- Tug or tow grounding;
- Loss of either tug or barge hull integrity;
- Collision
- Contact by the tug or tow with a fixed object, installation or navigational mark;
- Tidal cut;
- Reduced water levels in the river;
- Unexpected/sudden deterioration of weather conditions (wind/visibility/sea state).

Section Six – Testing, Inspection & Maintenance of Towing Equipment

6.1 Introduction

This guidance does not replace the recognised industry standards for testing, inspections and maintenance of towing equipment. Clydeport expects towage providers in the port adopt industry best practice.

6.2 Items to be Checked Before and After Towing

Before and after completion of any tow, industry recommends that all towing equipment is thoroughly checked for defects and general wear. This should include both the towing equipment onboard the tug and also the towing equipment aboard the vessel(s) to be towed. Towing companies are recommended to follow the British Tug Owners Association Best Practice Guidance Pre-Tow Checklist at Appendix 2. The following general guidance is the recommended minimum requirement:

Towing Hook

- Monitor the condition of the gear on a regular basis, especially wear and tear at the fulcrum pin and where the hook interacts with the guide track;
- Look out for stress fractures in the key stress areas i.e. the fulcrum pin and supporting structure;
- The smooth and efficient action of the quick release system (if applicable); and
- If applicable, an axe should be provided and be readily available for use.

Towing Winches

- Check the effective operation of the winch including braking mechanism and ‘in gear’ operations;
- Ensure the pawls on winches are effective and free to arrest the tension on the towing wire and are able to release with ease; and
- Look for excessive corrosion or fracturing of the winch hold down bolts and/or welds.

Bollards, Fairleads and Sheaves

- Check for excessive corrosion leading to the wasting of the bollard/fairleads and supporting structure;
- Look closely for fractures in both the bollard support structure especially around bollard pins; and
- Proper rotation of sheaves or other pulley devices such as snatch blocks and secure connection to deck or another tug structure.

Ropes and Wires

Undertake regular visual inspections of all reopens and wires, identifying frayed strands, distortion of wire/rope and condition of splices/mechanical wire splices, knots and shackles.

6.3 Recording of Inspections

The results of the towing gear and equipment inspections should be recorded in the daily log. Additionally, recorded in a dedicated folder for all towing equipment. Such data should be submitted to the owner/operating company as required.

6.4 Formal Testing and Maintenance of Towing Equipment

Testing

Towing equipment, such as hooks, winches and ropes should be provided with test certificates when new and should be tested and certified by approved contractor every 5 years. Test certificates should be kept for future reference and gear should be re-certificated either when the tug is re-engineered or if a serious defect occurs and subsequent repairs are completed, or as and when required by the licensing authority.

Tow ropes should be provided with test certificates, which it is recommended, are filed onboard the tug. Coils of rope, used for making up deck ropes, should also be provided with test certificates, although it is not necessary for individual deck ropes to be tested and certified.

Maintenance

Owners and operators should ensure that they have in place an appropriate towing equipment maintenance system for each vessel. Clear procedures should be in place for recording the required daily, weekly and other periodic checks and those checks require to be undertaken before each towing operation. Appropriate record forms and log books provided are to be maintained.

Maintenance of all towing equipment and associated gear should form part of the tug's weekly maintenance checklist, as a minimum. The maintenance carried out should aid in preventing premature failure or wear of towing equipment, which is subject to extensive loads during towing operations. Particular attention should be made to ensuring that towing equipment is free of excessive corrosion, all moving parts are regularly lubricated (this also applies to the core of wire ropes) and serviced.

6.5 Acceptable Safety Factors for Towing Equipment

It is recommended that steel wire and fibre rope towlines and towing springs have a Safe Working Load of at least 2 times the bollard pull of the tug involved in the towing operation. This also applies to towing hooks. A lesser safety factor can have a detrimental effect on the towlines lifespan, which may lead to failure of the towline during towing operations. The factor of safety may be reduced for deck lines and pusher tug connecting wires as the loads experience are greatly reduced.

Section Seven – Preparations before Commencing Towing Operations

7.1 Introduction

Before commencing towing operations, fundamental safety checks should be completed onboard both the tug and the craft being towed; supporting a safe and incident free towage operation. It is recommended that a dedicated operational Safety Management System is established on the tug, in order that proper checks and maintenance procedures are in place at all times.

7.2 Preparations Onboard the Tug¹

To ensure that the tug is suitably prepared for towing operations the following items should be checked prior to commencing a tow:

Watertight /Weather-tight Integrity

Watertight integrity of the tug must be maintained at all times. Particularly, when a vessel is engaged on any towage operation, complete watertight integrity must be assured. Crew must ensure all watertight openings are securely fastened. Openings must be clearly marked with a sign stating that they remain closed during towage operations. Any openings during a towage operation must be re-secured immediately after use. Clydeport supports all operators in the port develop a positive behavioural safety culture within their organisation and encourage this with all persons (crew and others) on their vessels.

Life Saving Appliances (LSA), Firefighting & Navigation Equipment

LSA and firefighting equipment required by the licensing authority must be provided onboard at all times and checked regularly as part of the vessel's daily, weekly and monthly procedures. All navigation equipment should be in date for calibration, be operational and checked regularly as per the licensing authorities and company's requirements.

Machinery

Prior to commencing any towing operation, proper checks must be made of the main engine and steering gear. These checks should include such items as oil/coolant levels, operation of main engine, gearbox, telegraph and steering gear and sea inlet/outlet flow. Whenever the main engine is running under heavy load, additional checks should be made of the engine temperatures. Details of the engine room checks should be recorded in a dedicated engine room log, which should be retained for future reference.

Towing Equipment

Section Five details the checks to be made on towing equipment prior to commencing a tow.

¹ . Reference to the Tug also includes workboats engaged as the towing vessel.

7.3 Preparations Onboard the Craft to be Towed

The owner of the craft and party with overall responsibility for the evolution (or delegee) must ensure that the towed craft is suitably prepared for towing operations. The following points should be checked prior to commencing a tow:

Water in Peak/Buoyancy Spaces

Before any person enters a space to check for presence of water, proper 'Gas-free' and confined space procedures must be strictly adhered. Peak tanks and other buoyancy spaces must be checked for water ingress. Any unintended water should be pumped out and disposed of in an environmentally approved way, prior to the tow commencing. Water left in the vessel will have a detrimental effect on the stability of vessel due to free surface effect. If a significant amount of water is observed in a peak/buoyancy space, the cause must be established and rectified as appropriate, prior to the tow commencing.

Watertight/Weather-tight Integrity

The craft to be towed must be checked to ensure that that all peak tank/cargo hatches and buoyancy spaces are properly secured prior to the beginning of a towing operation. The vessel should be checked for any obvious damage, especially in the case of a dumb barge. Damage (contact) can occur frequently evidenced in way of splits in the shell plating, especially on the deck join.

7.4 Loading Barges

Evolutions in the port, both river and firth, include the carriage of various cargoes on barges. Carriage of plant/machinery for marine construction and other special project cargoes is common.

Trim and heel can have a detrimental effect on the ability of a tug to maintain control of a barge under tow. Barges used in towing operations in the port should be loaded with no heel and a slight trim to the stern to ensure that the barge remains laterally stable when towed.

There are a very limited number of linkspan locations available to support loading of heavy equipment. Responsible parties must assess the limitations of all berths intended to support the evolution and satisfy themselves on suitability.

When loading barges, the operation should be supervised by a competent person trained to undertake the loading of craft. It is strongly recommended there is involvement of a person holding a Boatmaster's Licence and the necessary cargo endorsement.

A loading plan should be prepared and utilised so that the desired trim and even keel are achieved following the loading operation. This is especially relevant when considering the loading of bulk cargoes. Operators of such craft should ensure that loading plans are available for the range of barges utilised.

Limitations

A barge must not be loaded beyond allocated freeboard marks. If a barge is overloaded, cargo must be removed before navigating.

7.5 Spoil Cargo

Spoil cargo, particularly those containing a high level of moisture or become wet when left in open storage areas or where moisture is absorbed from the environment, can change the movement characteristics of the cargo. Where drainage is minimal and recognising drying from sunlight rarely does more than affect the surface, wet spoil cargoes will form a liquid or semi-liquid state when transported. Most barges are not designed to carry cargoes in a liquid or semi-liquid state and when this process occurs it will cause significant stability problems and may lead to barges capsizing and sinking.

Where a cargo of spoil is to be loaded and it is clear that the cargo contains significant quantities of moisture that may cause it to assume liquid type properties and affect the stability of the barge, the Tug Master, or other suitably competent person, should not load the cargo unless satisfied that the cargo will not present a hazard to the stability of the barge.

Spoil cargoes at risk of adopting liquid type properties when transported may be identified by conducting the “can test” as described in the International Maritime Solid BULK Cargoes (IMSBC) Code. This test involves filling a can with a cargo sample and banging it sharply on a hard surface from a height of about two feet. This should be repeated twenty-five times. If moisture is seen on the surface of the sample, then this indicates that the cargo may be unsafe for lading and should be made subject to further testing.

Where further testing is necessary, this may be undertaken to the requirements of the IMSBC Code; requiring the Flow Moisture Point (the point at which a material changes from a solid to liquid state) of the cargo to be measured against which the Transportable Moisture Limit (TML) – the level of moisture up to which it is safe to transport the material – will be determined. The moisture content of the material must be less than the TML to enable the cargo to be safely carried.

It should be noted that this test result is only relevant to the date of sample taken for test. Subsequent heavy rain on exposed spoil and other factors may cause an increase above the TML by the date of actual loading.

Whenever it is suspected that cargo with a high level of moisture content has been inadvertently laden, then it should be periodically monitored for the migration of moisture to the surface of the material. Where water begins to accumulate, this is an indication that the moisture content of the material may be too high and in excess of the TML. Water should be pumped out to reduce the impact of free surface effect on the barge. Consideration should also be given to postponing the voyage until it has been identified that the TML is not exceeded.

Section Eight – Crew Safety during Towage Operations

8.1 Introduction

All parties have a vital part to play, ensuring that safety is at the forefront of people's mind when considering their role in the lead-up and execution of a towing operation.

8.2 Working Hours

Regulations require Master and crew also to be properly rested. Note that the relevant Merchant Shipping regulations put responsibility on both the vessel operator (or owner) and the Master to ensure that the crew are suitably rested.

8.3 Safety of Personnel

All those with a responsibility for personnel or equipment involved in craft towage operations have a duty to ensure that safe working practices are followed, and that associated equipment is fit for purpose. There must be assurance that those involved in craft towage operations are properly equipped and trained to undertake the work.

Whilst the employer has particular responsibilities, all parties have a responsibility for their own personal safety and for those who may be working with them to support the evolution. It is incumbent on the Master to ensure the safety of the crew when they are onboard, but also when they are working at their direction; for example, on the craft towed, or on a jetty, berth or mooring buoy. The Master has a responsibility for the provision of crew Personnel Protective Equipment (PPE). Crew members are also responsible for ensuring that they have the appropriate PPE and for using it properly, looking after it and maintaining it in line with the manufacturer's instructions.

When on deck personnel involved in craft towage operations **should**:

- Wear approved and in-date self-inflating lifejackets and other appropriate PPE (e.g. hard hat, safety footwear, high-visibility clothing etc) throughout the operation;
- Ensure that the working area is safe and free from trip or slip hazards, particularly around bollards. Report any trip or slip hazards immediately to the Tug Master;
- Remain alert to ongoing operation, what is expected next and what fellow crew members are doing;
- Hold a line by the side of the eye or the standing part and if wearing gloves, ensure that they fit correctly; and
- Be aware of potential for lines (towing or mooring) to suddenly come under tension.

They **should never**:

- Stand in the bight or eye of a mooring line at any time;
- Walk over slack towing or mooring lines;
- Stand astride, stand on or walk over taut towing or mooring lines;
- Let a wire rope slit through the hands or slide a hand along a wire.
- Wear rings; and
- Stand in a "Danger Zone", i.e. in the area into which a tow line under tension could recoil. In this instance it is recommended that the "DANGER ZONE" is clearly indicated on each tug, this may be completed by highlighting the relevant deck areas.

8.4 Effective Communications

Onboard Communications

Effective communications are a vital component of safe towage and other shipboard operations. It is essential that the Tug Master provides clear and unambiguous instruction to his crew in planning for and undertaking towage operations. The methods of communication on board must be clear and effective and systems checked before operations commence.

Effective communication between the Tug Master and those onboard the tug is also particularly important whenever crew members are working onboard the towed craft, e.g. connecting or disconnecting the tow or mooring/unmooring the craft.

If using visual (hand) signals to communicate, all those involved must be fully conversant with the different signals and their meaning, which must be agreed in advance of the operation and be an established part of onboard operational procedures.

The Tug Master should keep his crew fully informed of any changes of plan during the towage operation and in particular, any unexpected and significant engine movements, helm orders or use of the anchors.

Reporting Tug Movements

Clydeport operates a Local Port Information service (LPS) on VHF Ch 12 coordinated from Peel Ports Group Port Control Centre in Liverpool. The tug should act as the reporting vessel giving details of their situation and intentions. As well as the mandated calls to Estuary Radio for departure, arrival and the designated reporting points (indicated on the Admiralty Charts and listed in Admiralty List of Radio Signals (ALRS) Vol 6), slow moving tows should update their progress (position, course and speed) to Estuary Radio on VHF Ch 12, every hour when operating north of the Cumbrae Gap and every 30 minutes East of No 1 Buoy in the River Clyde.

8.5 General Safety Provisions

Crew Safety during Towing Operations

Once the towing gear is connected, the crew should indicate this to the Tug Master, clear the area and, if required to remain on deck, stand in a safe position. If the crew are required to attend the towing gear during a towing operation, the length of time exposed should be kept to a minimum. In addition, it is recommended that operators adopt a 'clear deck policy' during towage operations, to prevent accidental slips/trips on deck or injuries from parted tow lines.

During towage operations the towing gear equipment and personnel should be continuously monitored and any change in circumstances immediately relayed to the Tug Master. This is particularly important on tugs where the Tug Master has a restricted view of the towing area/personnel. Crew should be aware that the tow may have to be released in an emergency situation, and that this may occur without warning.

Towage operations place significant loads upon ropes or warps, gear and equipment. The Code of Safe Working Practices for Merchant Seamen sets out certain precautions, which should be taken but the circumstances of recent accidents show that greater emphasis should be given to considering the system as a whole.

As a result of the imposed loads, sudden failure in any part of the system may cause death or serious injury to personnel. In any case, the consequences of failure in any part of the system must be carefully considered and effective precautions taken.

Tug Masters and crews are reminded of the need to remain vigilant when tow ropes and other lines become slack during the towage operations. This could occur when, for instance, way is taken off the tug and the tug is manoeuvring with the towed craft. When speed is increased, weight can unexpectedly come back on the lines, which can be a danger to crew on deck. In other circumstances, whilst the weight may come back on the lines in a controlled manner, the tow line(s) may become caught under an obstruction on the tug, or tow, and may suddenly recoil as the weight becomes excessive. When lines are slack they should be controlled by a member of the crew to ensure that they do not enter the water or become fouled on any obstructions.

8.6 Briefings/Tool Box Talks/Risk Assessments

Tug Masters and responsible persons are to ensure all the personnel involved are briefed on the conduct of the towing operation, including berthing arrangements and personnel transfers. All personnel involved must have seen the Risk Assessments and it is the operator/responsible person who must ensure this requirement is conducted.

For unusual towage operations, pre-tow consultations and briefings should be given with representatives from all parties attending.

Section Nine – Crew Safety during Towage Operations

9.1 Towage arrangements

There are no hard and fast rules regarding the make-up/arrangement of a tow of barges. The type and size of craft being towed and the manoeuvrability and power of the tug or tugs all have an effect. Essentially, the Tug Master must have input to decide on the best way to make up a tow of craft. Local conditions including available depth of water at a berth, bridge opening requirements, weather conditions, each have an effect on how a tow is best made up. There are general guidelines to determine appropriate towing arrangements/operations which should be followed where appropriate.

9.2 Position of Barges

Towing Barges

When making up a tow of barges of differing sizes and design the barges should be positioned in groups of a similar size and design. For instance, two similar sized barges in the front rank and two similarly sized barges in the rear rank. In this instance the larger barges should generally be towed in front with the smaller barges in the rear.

When towing a mixture of light and loaded barges, any loaded barges should always be made up in the first rank with any light barges making up the rear rank.

Tow ropes should be secured to the barge(s) in equal lengths and with the same number of turns and identical knots to ensure that the same amount of rendering of the tow rope when power is applied. Where more than one barge are being towed, the remaining barges should be made up into ranks using bridles, breast ropes and stern ropes as illustrated in Figure 2 & 3. Where necessary a stop rope (a line from the aft bollard on the tug to the head-post on the barge) or a gob rope (a line secured over the top of the tow rope on the aft deck of the tug; moving the towing point further aft) should be utilised to prevent the tug being overtaken by the barge(s) being towed.

Figure 2.

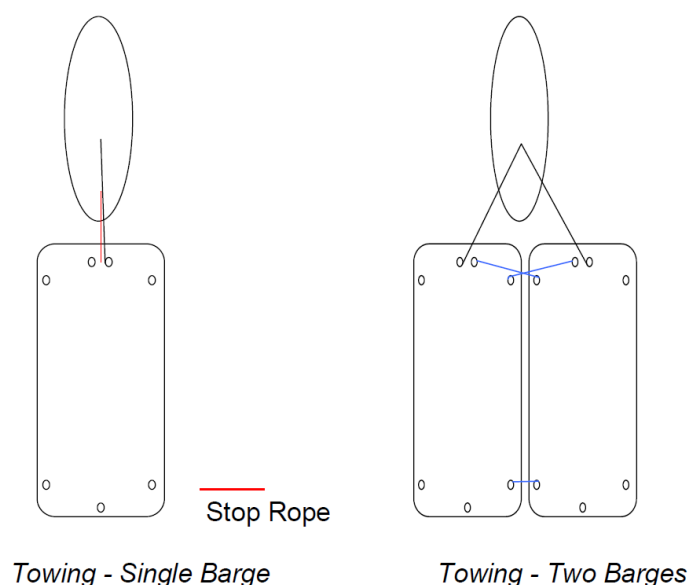
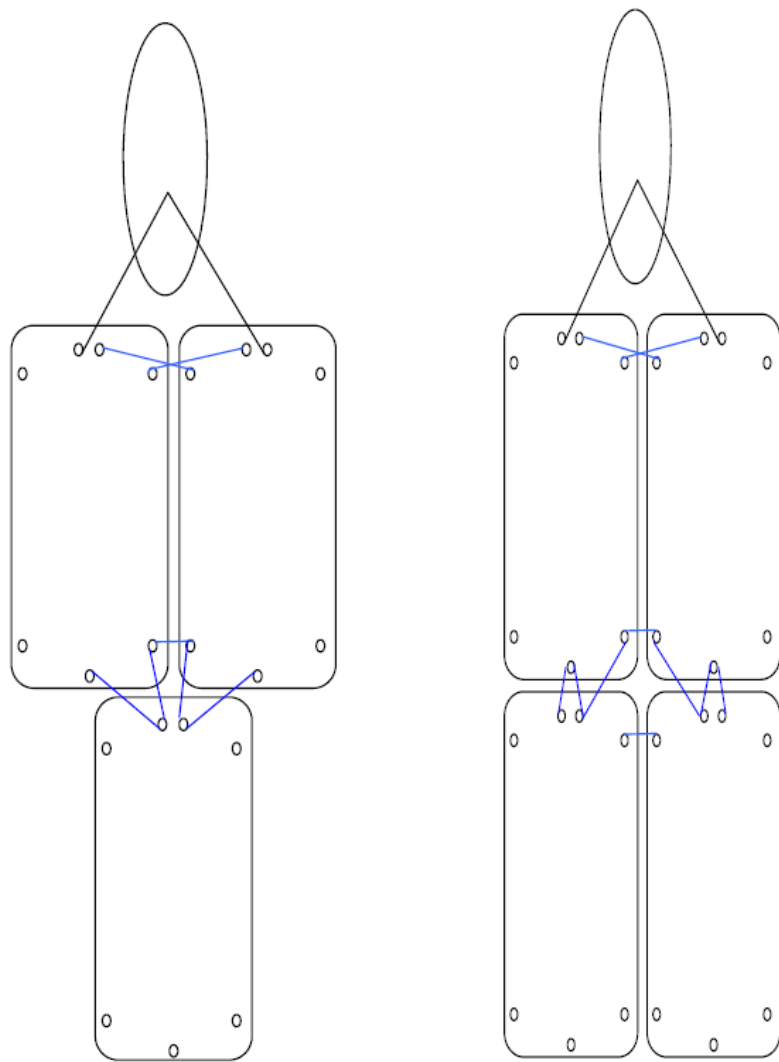

Figure 3.



Towing – Three Barges

Towing – Four Barges

Towing Alongside

Towing alongside should be undertaken using a suitable heavy spring, a head rope and stern rope. The tug should be positioned so that the stern of the tug just overhangs the stern of the barge. However, there are exceptions to this, for example, when considering the length of the tow or the direction in which you want the vessel to be able to turn the quickest. The further the tug is positioned forward the more difficult it is for the stern of the tug to direct the heading of the tow. Considerations should be given to this when making up a tow alongside. Figure 4 below shows the typical method for towing alongside.

Figure 4.

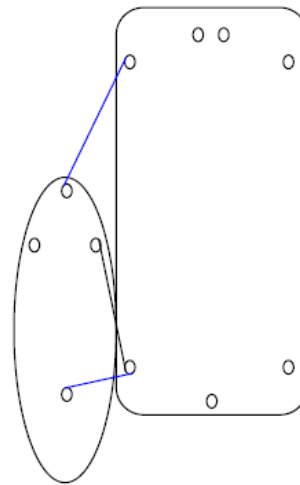

Towing Alongside

Pushing a Barge Ahead

When pushing a barge ahead the use of winches is recommended. This assists to ensure that the barge remains securely attached to the tug and that the tug and tow operate as a single unit during manoeuvres. The winch wires should be secured to the most outboard set of bollards of any pushed barge or combination of barges. In addition, there should be two substantial lines connected from the barge's port and starboard quarter bollards to the tugs head post preventing the horizontal movement of the tug across the huddis of the barge.

Figure 5 details the typical securing arrangements when pushing one and two barges ahead.

Figure 5.

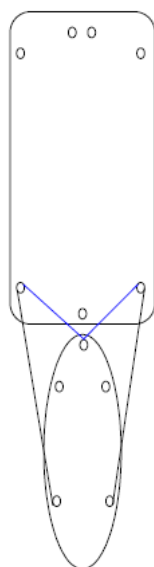

Pushing Ahead - Single Barge

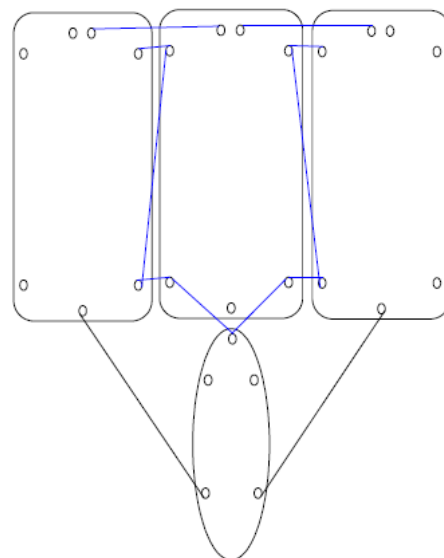

Pushing Ahead - Three Barges

9.3 Making Barges Fast Together

Barges should be made fast to each other through the use of non-jamming turns such as an 'over and under' or similar. The use of jamming turns such as a 'pin hitch' is not normally recommended due to the potential for the knot to jam when under tension and being unable to be released until the weight is removed. Care should also be taken to ensure that the correct lead, either up or down, is used when making up barges especially when a mixture of loaded and light barges is required in a tow.

9.4 Navigation Lights and Shapes

Tugs engaged in towing and the craft being towed, must carry the lights and shapes, as appropriate to the configuration of the towing operation and as required by the COLREGS Part C – Lights and Shapes.

Section Ten – Underway and Manoeuvring of the Tow

10.1 Introduction

When carrying out craft towage in the port it is essential to be aware of the tidal sets in the various reaches and also the local tidal conditions at individual berths. This is especially relevant when considering the towing of craft further up the River Clyde into Glasgow and through bridges.

Care should be taken when navigating with towed craft, especially when navigating around bends in the River. The tidal set in these areas may set craft into the bights of bends with the potential for grounding and contact with fixed structures or moorings resulting in possible injuries and damage to property or moored vessels in the area.

10.2 Manoeuvring Alongside

When manoeuvring alongside a berth, whether arriving or departing, the potential effects of wind (especially relevant with a light barge) and tide should be considered before undertaking any manoeuvre. Each individual berth will have its own physical properties, and thus tidal flow characteristics, dependent upon its position in the river and the prevailing tidal stream. In certain areas, a back eddy of tide may be present such that even when the tide is flooding there is still an ebb tide. Tug Masters should also exercise caution when manoeuvring close to dolphins, moorings or other structures (which can also create eddies) which may hinder or have an adverse effect on the approach to or from a berth.

10.3 Pushing Ahead or Towing Alongside

When pushing a barge ahead or towing alongside, visibility from the tug is often restricted. In such circumstances, a lookout(s) should be posted such that a proper lookout is maintained, and any blind spots eradicated. The lookout should have a sufficient means of communication with the Tug Master at all times. This is a requirement under Rule 5 of the COLREGS.

10.4 Craft Tug Towing Limitations

Before carrying out a towing operation in port, consideration should be given to the size of the tow and the tug being considered for use in the towing operation. Particularly, the responsible party must ensure that the tug is powerful enough to safely undertake the tow. All details and calculations should be submitted in the Tow Notification Form. It remains the responsibility of the Tug Master and responsible person to ensure the towing vessel is fit for purpose for the tow required, notwithstanding any consent of Clydeport for the evolution to proceed.

10.5 Towing in Rough Weather

Causes of Rough Water

The water surface of Firth and River Clyde can be affected by any number of factors, which may include:

- Swell from passing craft;
- Rip tides where there is an undercurrent or obstruction present below the surface;
- Undertows/wash bouncing off river embankments;

- Strong winds, particularly from northerly and southerly directions for the Firth of Clyde and easterly or westerly directions for Tail of the Bank and the River Clyde towards Erskine Bridge; and/or
- The action of wind against tide.

Effects of Rough Water

The effects of rough water on a tug and tow can be significant and may include the following:

- The effect on the tugs or towed craft's stability due to surface water and spray on deck. In extreme cases this may include green water over the bow of the tug and barge;
- The tugs and barges being moved on the vertical plain at different times to each other, thus placing extra strain on the towing and mooring lines; and
- Damage caused to the tug and barges as they are forced against each other by rising swells.

Actions to Minimise or Avoid Damage in Rough Weather

In order to reduce the risk to safety and potential damage when towing in rough or inclement weather, Tug Masters should take the following precautions:

Preparation

Extra care in preparing for towing in rough weather includes:

- Checking the local weather forecast regularly prior to departure;
- Securely stowing all moveable objects on deck and below;
- Closing and securing all external hatch-ways, doors and windows and vulnerable ventilators;
- Closely inspecting all towlines to ensure they are sound and undamaged, secure the barges to the tug and to each other with extra lines to compensate for their random movement in rough weather;
- Sheeting up the forward end of the main hatch coaming to reduce the amount of spray and green water entering the hold; and
- Additional lines available to cover the increased risk of lines parting.

Execution

During the tow it is still possible to minimise or avoid damage to the tug and barge by taking the following action:

- Delay departure until the wind decreases or changes direction or depart at a different state of tide;
- Reduce power/speed during the tow this will aid in reducing the amount of movement in the tow;
- If towing, lengthen the towlines to compensate for the tug power surge caused by the swell; and/or
- Call Estuary Radio to obtain advice from Clydeport and/or update on weather forecast and conditions elsewhere in the Clyde (Weather Stations are situated at; Ardrossan, Hunterston; Greenock; Rothesay Dock and King George V Dock, Glasgow).

Clydeport may impose restrictions on towage of certain craft in adverse weather.

10.6 Towing East of No1 Buoy

East of No1 Buoy is the start of the dredged channel of the River Clyde. It is narrow with little room for manoeuvre when controlling unwieldy barges or dead-ship vessels. Clydeport may require Pilot support services are provided for that part of the passage.

Clydeport may require for river transits, local towage companies will take over the towing operation from the sea tug. A trailing tug, if not a composite unit, will be required.

Use of sea tugs will only be assessed on a case by case basis but would likely require an additional pilot to assist the Master who would have no or little knowledge of the river whilst the main pilot would be onboard the tow. Sea going tugs are not normally designed for manoeuvring in harbour areas and any sea going tug proposed would need to demonstrate ability to safely work within the river and dock areas to an equivalent of a harbour tug.

10.7 Towing North of Cumbrae Gap to Kempock Point

For sea tows entering the Port, tows may be shortened at Tug Master's discretion before entering the Firth of Clyde/ Cumbrae Gap. If the Tug Master can shorten in the tow so that the total length of the towing vessel, tow line and towed vessel is less than 120m LOA, pilotage is not required until Kempock Point, although on a case by case basis, it may be prudent to embark the Pilot south of the Cowal buoy to ensure that the area of high ferry traffic density is safely navigated.

Tug Masters must navigate with extreme caution and with due regard to their circumstances including presence of naval and other traffic, on passage past Cumbrae Gap.

10.8 Towing in Restricted Visibility

Clydeport will not allow Towing within its jurisdiction if visibility is 1nm or less, or, if it is forecast to be 1nm or less on any of the legs of the voyage.

In the event of being caught in visibility of less than 1.0 nautical mile, a dynamic risk assessment should be made to find a safe haven / location, outside any of the main channels/fairways, to halt towing operations, if safe to do so, until visibility improves. Intentions must be reported to Estuary Radio on VHF Channel 12.

10.9 Clydeport definitions of Day and Night Operations

Day time Towing operations means from Start of Civil Twilight to End of Civil Twilight.
Night time Towing operations means from End of Civil Twilight to Start of Civil Twilight.

Section Eleven – Mooring Barges

11.1 Introduction

Mooring and unmooring barges presents significant operational risk. Slow moving heavy objects and crew members can come into contact with each other, with serious consequences. This activity must be properly assessed, managed and executed with extreme caution. Experience has demonstrated the potential for complacency.

All of the commercial berths in the Clyde are tidal berths, with some more shelter from tidal stream effect than others.

11.2 Mooring Barges alongside Tidal Berths

When mooring at a tidal berth consideration must always be given to the expected tidal conditions at the material time(s). This should include the predicted rise and fall of tide on that berth during the craft's total period alongside. Assessment whether the craft will take the ground during this time, the available mooring equipment and the condition of the ground at the berth.

In instances where similar craft are used frequently at berths, mooring plans should be drawn up to ensure that craft are consistently moored in the best way possible. However; full account should always be taken of the potential for changing or anticipated environmental conditions, including: tidal surges and weather, in such instances additional precautions must be taken.

The mooring arrangements for tidal berths on the Clyde are generally provided in one of two ways; standard fixed bollards located at the top of the berth or mooring travellers located on the face of a wharf or jetty. In each case, the craft will need to be moored so as to allow for the force of the tidal flow while allowing for a mean tidal range of between 3.1 in the Greenock area to 4.1 metres up the River Clyde in Glasgow. Extraordinary climatic conditions can vary ranges significantly to those predicted.

Fixed Bollard Arrangement

When mooring on a tidal berth with a fixed bollard mooring arrangement, long leads from the barge to the berth are essential to ensure that a barge does not get 'hung up' on its mooring lines at low water. These should generally consist of a head rope from the towing post and a stern rope from the stern post. In addition, two long springs should be positioned from the vessels inner quarter posts. When making these lines fast a 'back turn' is recommended to ensure that the mooring lines will not jam on the upward lead to the bollard. See Fig 6.

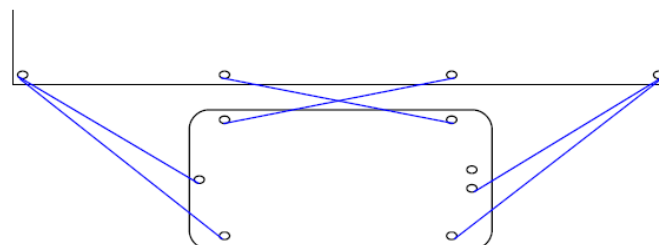

Mooring Arrangement at a Berth equipped with Bollards

Figure 6.

Mooring Traveller Arrangement

The mooring arrangement for a tidal berth equipped with rising travellers differs only in that instead of utilising two long springs to hold the craft to the berth breast ropes are deployed from the craft's quarter posts to the rising travellers thus enabling the barge to rise and fall with the tide alongside the berth. See Fig 7.

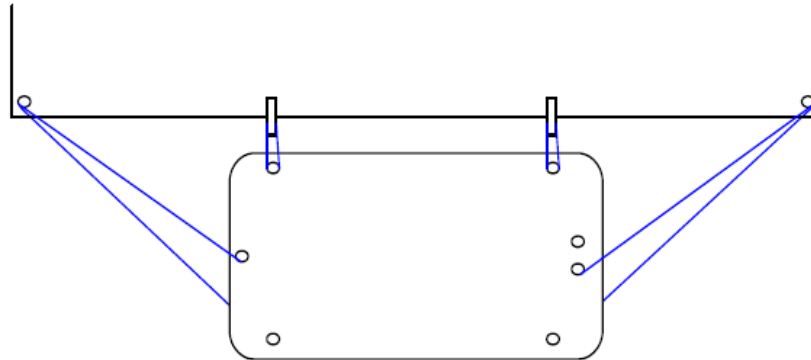

Mooring Arrangement at a Berth equipped with Mooring Travellers

Figure 7.

11.3 Shearing Barges at a Tidal Berth

Due to tidal constraints at some berths, it is not always possible for the tug to get to a berth to moor or retrieve a barge. In these cases, barges are often sheared into or off a berth using a combination of the tide and assistance from the tug.

Shearing a Barge into a Tidal Berth

Provided there is sufficient depth of water at a berth to accommodate a barge, the Tug Master may choose to shear a barge into a berth. Should this option be utilised, then competent bargemen must be present onboard the barge(s) at all times during the manoeuvre. To shear a barge into a berth the bargemen should ensure that sufficient headway and direction is given to the barge to bridge the gap between the tug and berth. This manoeuvre should always be undertaken against the tide such that the tide acts on the budget of the barge ensuring that the direction is maintained.

Care should be taken to ensure that the angle at which the barge cuts across the tidal stream is kept to a minimum. The tidal effect on an excessive angle may cause the head of the barge to angle too far in towards the berth resulting in a heavy impact. The bargemen should ensure that they have a fender and mooring line prepared for deployment when the barge reaches the berth.

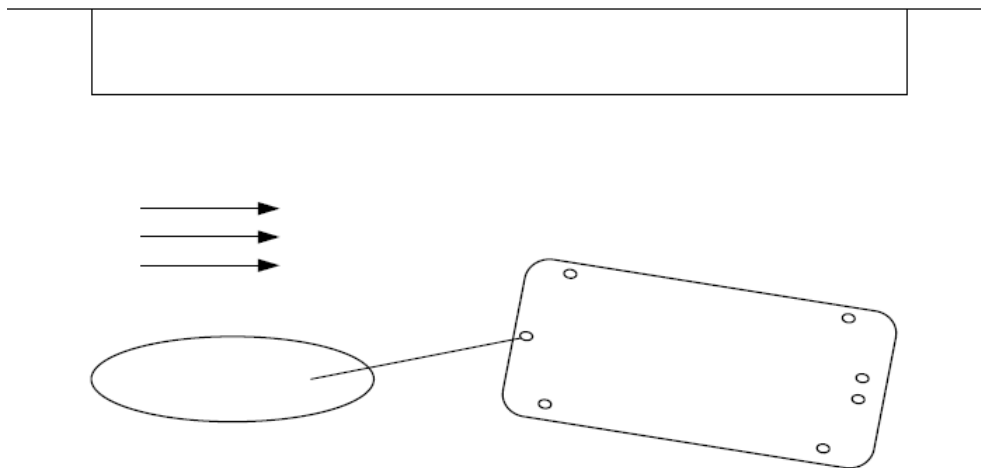

Shearing a barge into a Tidal Berth

Figure 8.

Shearing a Barge from a Berth

Where a tug is unable to secure a line to a barge due to tidal constraints, it is possible to shear a barge into the river where it may be secured to a waiting tug. To undertake this manoeuvre the barge should be manned by competent bargemen and the receiving tug should be suitably prepared to receive the tow. As with shearing a barge from a tug to the berth, this manoeuvre must only be undertaken with the barge head into tide and with a good communication link established between the tug and bargemen. The barge should be sprung off the berth (keeping the spring line fast) in order to achieve the desired angle, such that the tide is able to act on the barge to aide it into the river. Care should be taken to ensure that the angle of the barge in relation to the tidal direction is not too great such as to become an issue. When the barge reaches the waiting tug it should be secured such that the barge may be taken in to tow.

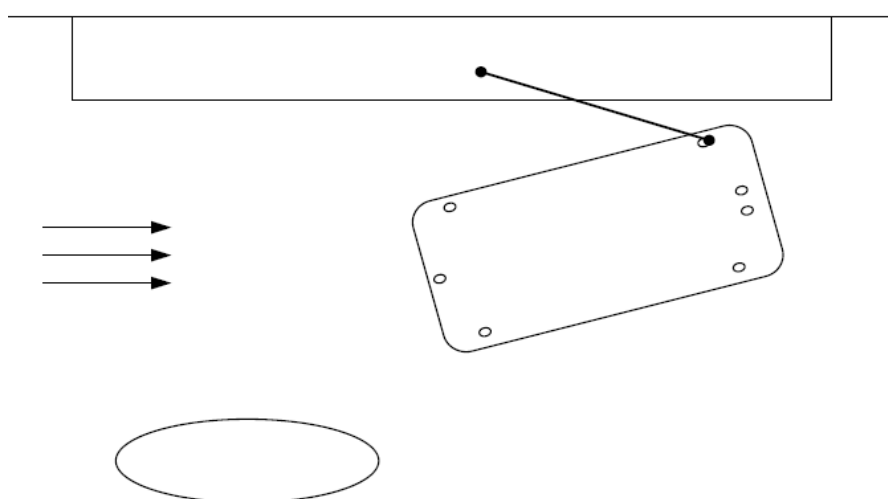

Shearing a barge off a Tidal Berth

Figure 9.

11.4 Mooring Barges in the Clyde

There are no commercial pre-planned designated locations in the Clyde for temporarily mooring barges either in the short and medium term. However, the Queen's Harbour Master in the Dockyard Port area, has moorings at Gareloch and Loch Goil for Ministry of Defence use.

For long term layups operators should contact Clydeport Marine Office via email: ClydeMarineManager@peelports.com to make an appointment to call and discuss any proposals.

Section Twelve – Further Guidance and Advice

Further guidance and advice can be found in the following publications:

- Code of Safe Working Practices for Merchant Seamen.
- Current relevant Merchant Shipping Notices, Marine Guidance Notes and Marine Information Notes.
- Port Marine Safety Code and supporting Guide to Good Practice.
- Management of Health & Safety at Work Regulations 1999.
- British Tugowners Association Best Practice Guidance – Pre-Towing Checklist
- Witherby Seamanship Pilots’ Pocket Guide and Checklist.
- Inland Waters Small Passenger Boat Code.
- The Workboat Code Industry working Group Technical Standard.
- National Workboat Association – The use of Workboats for Towage – Good Practice Guide.
- The Shipowners Club – Loss Prevention Tug and Tows – A Practical Safety and Operational Guide.
- UK P&I Club – Tug and barge matters – A focus on some of the issues surrounding tug and barge fleets in the P&I world.
- Peel Ports Website www.peelports.com
- MAIB Reports into the IJSELSTROOM, LLANDDWYN ISLAND and CHIEFTON incidents.
- International Maritime Solid Bulk Cargoes (IMSBC) Code.
- Transport Canada – TP11960E (01/2017) Standards for the Construction, Inspection, and Operation of Barges Carrying Oil or Dangerous Chemicals in Bulk.

ANNEXES

- A. British Tug Owners Association Best Practice Guidance – Pre-Towing Tasks Checklist

APPENDICES

1. Clydeport Tow Notification Form
2. Peel Ports Marine Accident Report Form
3. Marine Guidance Note 564(M+F) Marine Casualty and Marine Incident Reporting.

BRITISH TUG OWNERS ASSOCIATION

BEST PRACTICE GUIDANCE - PRE-TOWING TASKS CHECKLIST

Members may wish to note that the agreed checklists and assessment criteria for general towing tasks is now available on our website. These checklists provide an overview on checks that should be carried out prior to commencement of harbour related towing operations.

Individual companies may wish to use their own checklists and use this as a cursory guide to ensure that they are in compliance with the basic safety standards.

The Pre-Towing Tasks checklist is in four parts;

- 1) Prior to undertaking tow and during passage
- 2) Fitness for Purpose and verification of documentation prior to commencement of Towage
- 3) Verification of Internal and External communications
- 4) Review of Emergency procedures

BTA's Pre-Towing Tasks Checklist

1) Safe Towing Operations Checklist

No	Task / Duty	Officer Signature	Date
When preparing to undertake a towage operation.			
1	Identify the principle risks and method of assessment		
2	Identify and understand the reasons for the towage method to be used		
3	Visual inspection of the towing wire		
4	Identify suitable towage points and the chafing areas		
5	Identify the characteristics of the tow		
6	Ensure rigging and correct deployment of the towing gear		
7	Knowledge of safe handling of the towing gear		
8	Identify safe areas on deck		
9	Ensure adequate lighting of working areas		
10	Identify the stability of the tug and tow		
11	Prepare a passage plan		
12	Identify local byelaws that may affect the operation		
13	Identify where different phases of the tow may require different towing requirements		
14	Identify berthing arrangements on arrival		

On Passage			
15	Follow correct procedures to connect, let go and change of the towing gear		
16	Monitor the tow to take timely and effective corrective action when required		
17	Aware of the importance of avoiding large dynamic forces on the tow line		

2) Fitness for Purpose Checklist

No	Task / Duty	Master Signature	Date
For an intended passage:			
1	Check correct documentation for the tug		
2	Check correct documentation required for the tow		
3	Verify tug requirements for the tow		
4	Assess fitness and suitability of navigation equipment for proposed passage		
5	Assess number, experience and qualifications of crew		
6	Assess the suitability of the towing equipment		

3) Internal and External Communications Checklist

No	Task / Duty	Master Signature	Date
Verify Internal Communications			
	Conduct:		
1	A pre-tow briefing with crew		
2	The use of hand signals and state the importance of non-verbal signals		
3	The use of hand held radios and state the importance of correct radio procedures		
4	The use of on-board CCTV		
5	The use of on-board alarms, signage and announcements		
Verify External Communications			
	Ensure:		
1	Tow set up briefing with external stakeholders		
2	Agreement of terminology with pilot		
3	Check communications with other tugs and vessels		
4	Check traffic reports and communications with Port Control/LPS/vessel		

4) Emergency Procedure Checklist

No	Task / Duty	Master Signature	Date
Verify Actions to be taken in the event of:			
1	Failure of towing lines and equipment		
2	Failure of gog arrangements		
3	Failure of engines, steering, electrical systems		
4	Failure of steering gear		
5	Failure of electrical systems		
6	Loss of external communications to Pilot/Port Control etc		
7	Mechanical problem on the towed vessel		
8	Rope in propulsion system		
9	Compromise of watertight integrity of tug when towing		
10	Collision		
11	Ground of tug and/or tow		
12	Man overboard		
13	Fire		
14	Pollution		
Verify:			
15	Use of the emergency controls		
16	Deployment of the emergency tow line		
17	Emergency release of the tow procedure		
18	Crew preparedness at emergency stations		
Awareness of:			
19	The statutory requirement to render assistance		
20	The difference between responding to a Mayday and rendering salvage assistance		